

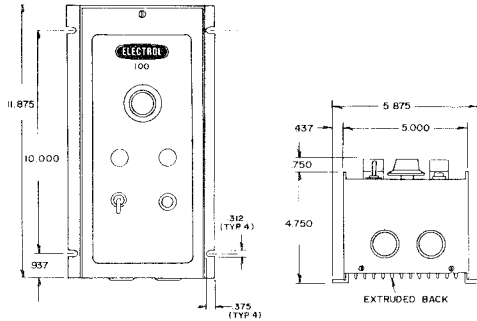

INSTALLATION & MAINTAINENCE MANUAL

MODEL CMH-C-100-E
MODEL CMH-3-100-CM
MODEL CMH-C-120-E
MODEL CMH-3-120-CM

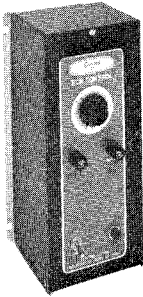

Standard Features

100 Series

- **Input Voltage** – 115V AC, 50/60 Hz, Single Phase
- **Output Voltage** – 0-90V DC PM or Shunt Wound Motors (Field Voltage 0-100/50V DC)
- **Horsepower Range** – 1/6 - 1 HP Multi-HP or Individually Rated

120 Series

- **Input Voltage** – 230V AC, 50/60 Hz, Single Phase
- **Output Voltage** – 0-180V DC PM or Shunt Wound Motors (Field Voltage 0-200/100V DC)
- **Horsepower Range** – 1/4 - 2 HP Multi-HP Selectable or Individually Rated
- **Speed Regulation** – 2% of Base Speed
- **Speed Range** – 50:1 Constant Torque
- **Full Wave Rectification**
- **Minimum Speed Adjustment** – Sets low end speed adjustment
- **Maximum Speed Adjustment** – Sets high end speed adjustment
- **IR Compensation** – Adjustable No Load to Full Load RPM
- **Torque (Current Limit)** – Adjustable Maximum Current Cut-off
- **Built-in Transient and Surge Protection**
- **Built-in Line Voltage Compensation**
- **Fuse Protection** – Line and Motor
- **On-Off Switch**
- **Master Speed Pot**

WARRANTY

ELECTROL controls are warranted by ELECTROL CO., INC. to the original user against defects in workmanship or materials under normal use (rental excluded) for one (1) year after purchase.

Any part which is determined to be defective in material or workmanship must be returned to ELECTROL headquarters, or an authorized service center, as ELECTROL designates, shipping costs prepaid. The control will be repaired or replaced at ELECTROL's option. Expenses incurred by buyer in repairing or replacing any defective product will not be allowed except where authorized in writing and signed by an officer of the company.

APPLICATION INFORMATION

1. If you replace an AC induction motor with a DC motor and adjustable speed drive, consideration must be given to the full load torque rating of the AC induction motor that is being replaced. The full load torque rating of the DC motor must be equal to or greater than the full load torque rating of the AC motor it is going to replace.
2. When replacing an AC induction motor with a DC motor and adjustable speed control the DC motors starting torque must be limited to 200% of full load torque (150% of full torque for gearmotors). The reason for these limits is to protect the motor or gearmotor from damaging overloads. Cycle type loads should be avoided.
3. Soft Start — The DC motor accelerates from 0 to full load RPM smoothly and takes 1 to 3 seconds to reach full load RPM. Acceleration rate varies with respect to speed setting and amount of inertia in the system.

4. The motor controller has circuitry to protect it from normal line surges, and transients. If, however, the control will be used in an environment where these are present constantly, such as high frequency welding equipment, an isolation transformer or other line filtering device should be used.
5. The Electrol adjustable speed DC motor control is designed for use on constant (or diminishing) torque applications such as conveyors, fans, blowers, etc.

WARNING: NOT INTENDED FOR USE WITH SAWS, DRILL PRESSES, OR OTHER CONSTANT HP APPLICATIONS. NOT TO BE USED IN AN EXPLOSIVE ATMOSPHERE!

If your control is equipped with DYNAMIC BRAKING, the following applies: Use only on motors up to 1 HP.

Dynamic Braking functions in the control when the FWD/BRAKE/REV switch is moved to the BRAKE position while the motor is running. This allows the motor to come to a quick smooth stop.

NOTE: Dynamic braking resistors are sized to function on the basis of no appreciable external inertia. The following is the maximum allowable motor starts and stops:

1/6 - 1 HP DC motors — 5 per minute max.

CONNECTION

CAUTION: Disconnect power source before connecting controller or motor. Use No. 12 AWG (minimum size) wire for controller input lines, and for interconnection lines between controller and motor.

Make connections to the controller and the motor in accordance with the Connection Chart. The controller terminal strip is located inside the controller enclosure. To reach the terminal strip, loosen the captive screw in the top of the controller front panel, then swing the panel open. To feed wiring to the terminal strip, remove the two button plugs from the bottom of the controller enclosure.

CUSTOMER CONNECTION AND ADJUSTMENTS

CAUTION: Follow local electrical codes and proper electrical practices during hook-up of controller. The customer is responsible for supplying and connecting an external power disconnect, such as a 20 Amp circuit breaker or DPDT toggle switch. Disconnect power source before connecting control and motor. Use #12 gauge wire for input lines to the control and lines to motor armature. The control features line and motor fuses, power on indicator light, power on/off switch.

TERMINAL BLOCK CONNECTIONS:

Customer Hook-up: L1-L2 Single Phase AC Input
A1-A2 Motor Armature
F1-F2 Motor Field (Shunt Wound)

ADJUSTMENTS:

Controls are shipped set up and adjusted for 1 HP, 115VAC. If any other horsepower and/or voltage is desired, follow the instructions below:

A. Horsepower Selection: 100 Series



1/8 & 1/8 H.P.



1/4, 1/3, & 1/2 H.P.



3/4 & 1 H.P.

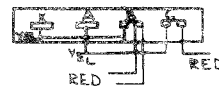

1 H.P.

Horsepower Selection: 120 Series

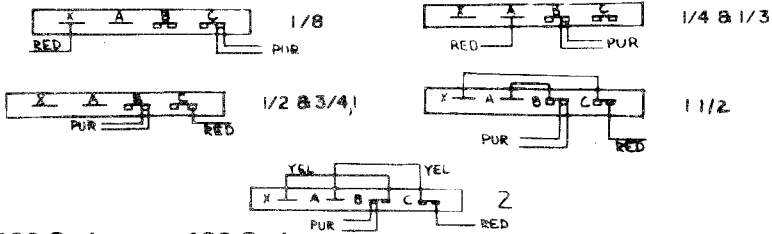

100 Series 115V	120 Series 230V	FUSE	
HP	HP	LINE	ARM.
1/6	1/4	3	3
1/4	1/2-3/4	5	5
1/3-1/2	1	10	10
3/4	1-1/2	15	10
1	2	20	15

B. Voltage Selection:

For 115V - 100 Series

For 230V - 120 Series

C. Start-up procedures:

1. Set master speed pot to 0%.
2. Apply power to unit.
3. Turn speed pot up and check for proper rotation of motor shaft. Reverse motor leads to change rotation, if necessary.
4. Trim pot adjustments, if necessary.
 - a) MIN RPM Trim: To adjust master pot low end speed range, turn CCW to decrease speed range. Turn CW to increase speed range.
 - b) MAX RPM Trim: To adjust master pot high end speed range, turn CCW to decrease speed range. Turn CW to increase speed range.
 - c) TORQUE Trim: To adjust maximum current available to motor armature, do not exceed full load current of motor.
 - d) IR COMP: To maintain no load motor RPM with load applied, turn CW to increase compensation. Turn CCW to decrease compensation. CAUTION: Overadjustment will cause motor RPM at low speed settings to rise excessively under full load conditions.

D. Dynamic Braking and Manual Reversing (MRDB) options:

When specifying the Manual Reversing Dynamic Braking (MRDB option), note the Forward/Brake/Reverse switch is rated for 3/4 HP. Max. If the master speed pot is set at zero and motor completely stops, the MRDB switch may be used for 1 HP.

The Dynamic Braking Resistors on the standard options are intended for intermittent operation. If continuous braking operations are necessary, a larger Dynamic Braking resistor will be required.

See options A-19 and A-20 in ELECTRO-LINE Catalog for additional information.

To Request Schematic
Please call or write:

Electrol Co. Inc.
321 Dewey St.
York, PA 17404

Phone (717) 848-1722
Fax (717) 848-4514
E-mail electrol@electrolco.com