



**D-TROL II
SERIES 225**

AVAILABILITY: FACTORY AND DISTRIBUTOR STOCKS

DC Motor Controller

3-5 HP

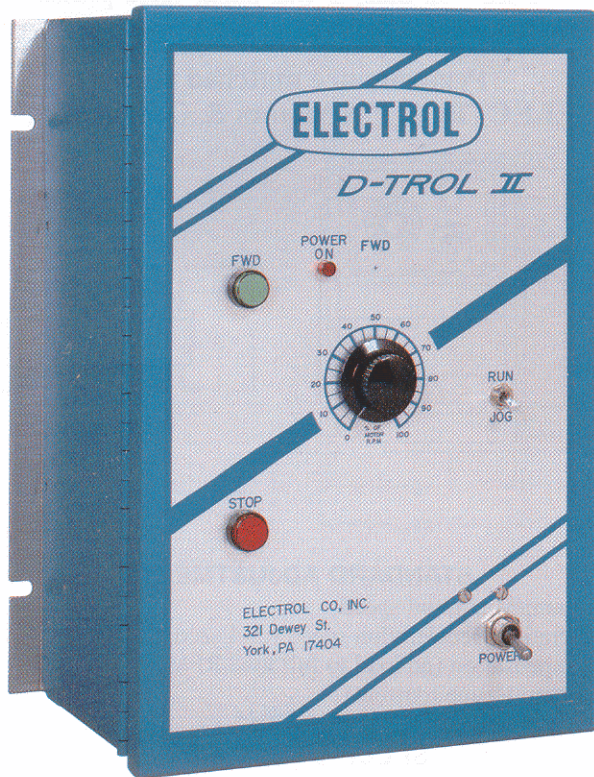

Performance matched with
ELECTROL PM Motors & Gearmotors

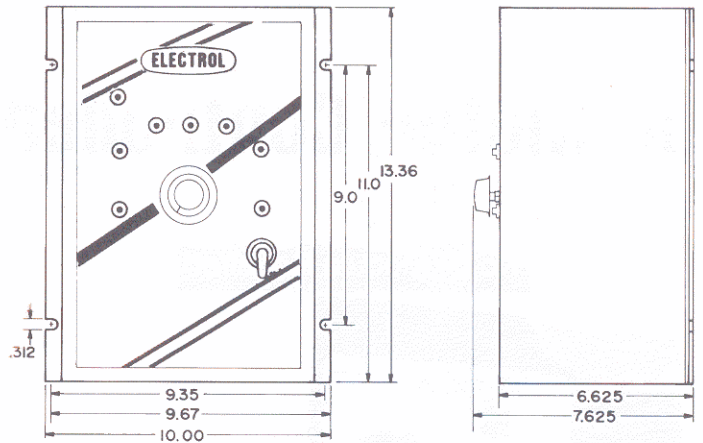

Reliable control for DC motors in Specialty Machinery, General Industrial Machinery, Measuring and Dispensing Pumps, Woodworking Equipment, Packaging Machinery, Conveyors, Commercial Equipment and Industrial Process Furnaces and Ovens.

STANDARD FEATURES

- Multiple horsepower rating
- 28 amperes (DC) continuous rating 2 regulation of base speed
- 30:1 speed range (constant torque)
- Transient and surge protection
- Line voltage compensation
- "Start" and "Stop" pushbuttons
- "Power On" switch and indicating light
- "Jog/Run" switch (jog at run speed)
- Restart protection - manual restart required after power loss

STANDARD ADJUSTMENTS

- Minimum/Maximum speed
- Acceleration/Deceleration speed (.5-15 sec.)
- IR compensation (no load to full load RPM)
- Maximum torque (current)

For optional features, refer to pages C-9 through C-16
For renewal parts, refer to page C-17

NEMA 12 Enclosure

COMPONENT RATINGS				
Rated Horsepower (HP)			1/8	1/4
Rated Kilowatts (KW)			0.124	0.187
1-PHASE AC INPUT (FULL-LOAD)	Line Amps	115V Unit	-	-
		230V Unit	16.0	30.0
	KVA			3.68
DC OUTPUT (FULL-LOAD)	Motor Armature Amps	90V	-	-
		180V	14.4	25.0
	Motor Field Amps	100V	-	-
200V		2.0	2.0	
FULL-LOAD TORQUE (lb-ft) with 1750 RPM Base Speed Motors			9.0	15.0

Part No.	Style	HP	WEIGHT	
			Lbs.	Kg.
C-3/5-YA-225-E	Enclosed	3-5	10	4.97
C-3/5-26-225-CM	Chassis Mount	3-5	8	3.98