



**STANDARD SPECIFICATIONS
SERIES 500**

AVAILABILITY: STOCK

Performance matched with
ELECTROL Motors & Gearmotors

DC Motor Controller

1/50-1/4 HP

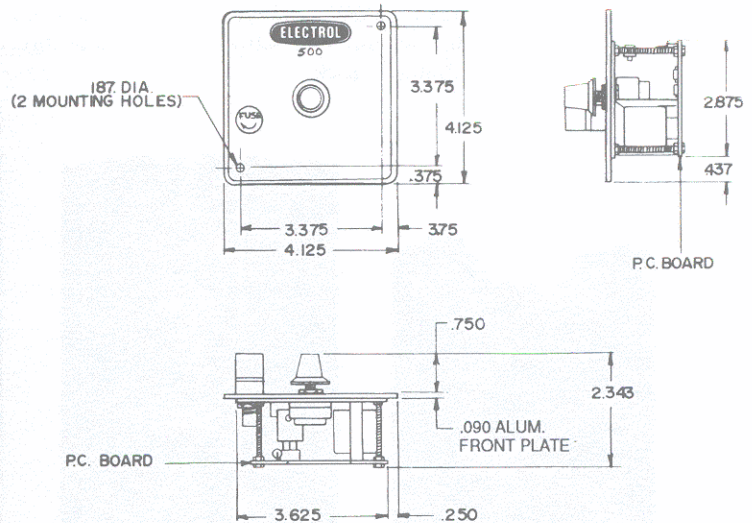
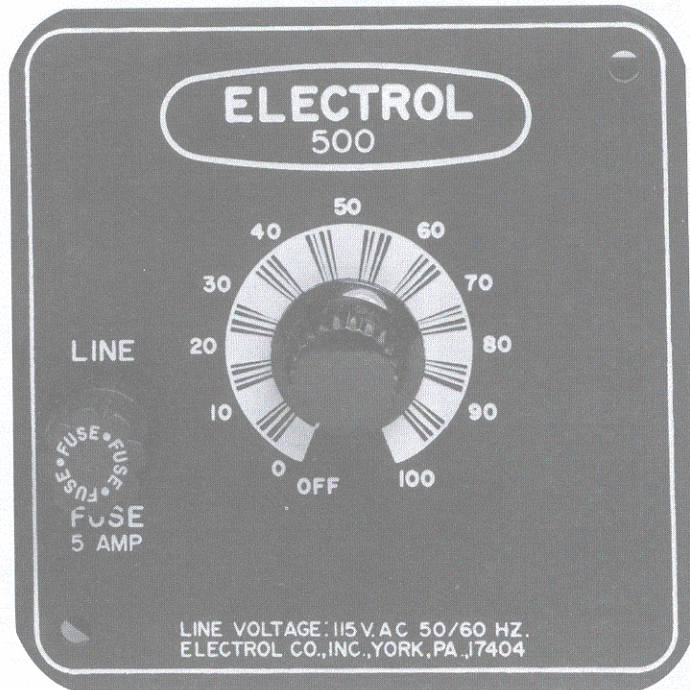

STANDARD FEATURES

- Multiple horsepower rating
- 3 amperes (DC) continuous rating
- 5/8% regulation of base speed
- 30:1 speed range (constant torque)
- Transient and surge protection
- Line voltage compensation
- Fixed Acceleration
- Fuse protection on line circuits
- 5k ohm, .5 watt master speed potentiometer with "On-Off" Switch
- Front plate fits double size "Handy Box"

STANDARD ADJUSTMENTS

- Minimum speed
- Maximum speed

For optional features, refer to pages C-9 through C-16
For renewal parts, refer to page C-17

115 VAC Input/90 VDC Output

Model	HP	WEIGHT	
		Lbs.	Kg.
C-MH-16-500-FP	1/50-1/4	1	.45
C-MH-P-500-E	1/5-1/4	1	.45