

AVAILABILITY: STOCK

DC Motor Controller

1/30-1/4 HP



Performance matched with
ELECTROL Motors & Gearmotors

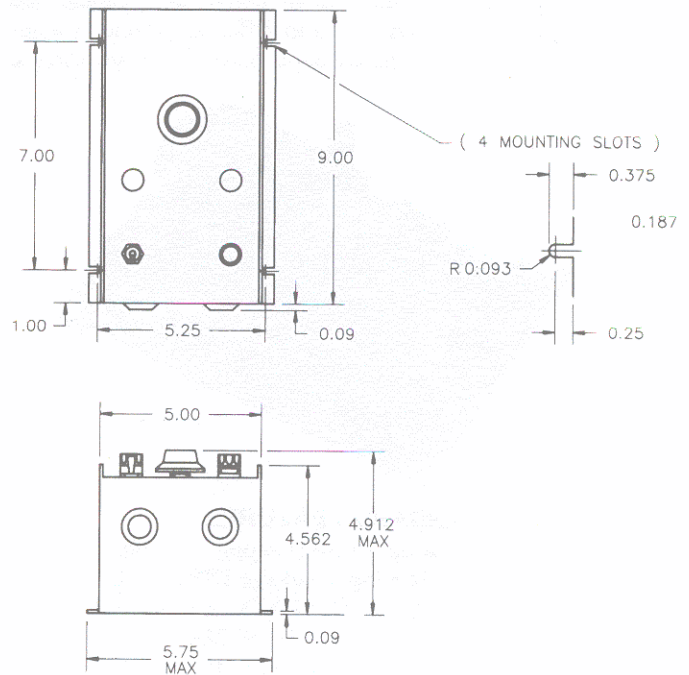

STANDARD FEATURES

- Multiple horsepower rating
- 3 amperes (DC) continuous rating
- 2-3% regulation of base speed
- 30:1 speed range (constant torque)
- Transient and surge protection
- Line voltage compensation
- Fuse protection on line and motor circuits
- "On-Off" power switch
- 5k ohm, .5 watt master speed potentiometer
- NEMA 1 enclosure

STANDARD ADJUSTMENTS

- Minimum speed
- Maximum speed
- IR compensation (no load to full load RPM)
- Maximum torque (current)

For optional features, refer to pages C-9 through C-16
For renewal parts, refer to page C-17

OPERATING VOLTAGES

POWER SOURCE (single-phase)	OUTPUT VDC	
	Armature	Field
115V, 50 or 60 Hz	0-90	100/50

Part No.	Style	Multiple Horsepower	WEIGHT	
			Lbs.	Kg.
C-MH-A-310-E	Enclosed 9" x 5" x 4-1/2"	1/30, 1/15, 1/8, 1/6, 1/4	4	1.81